

NEW

IN THIS CATALOG

OVER 20,000 ADDITIONAL ITEMS!



Patent
Pending

CleanLine UltraPlus™

*Ultimate Pharmaceutical,
Food and Meat Processing
and Washdown Solutions!*

See Section "O"



Spartan™ Worm Gear Drives

*Compact, Rugged and
Lightweight Alternatives
for Design Flexibility!*

See Section "C"



Poweratio® 2000 & 4000

*A Complete Family of High Efficiency
Gear Drives, Helical In-Line, Helical
Bevel, Helical Worm and Now Compact
Helical Parallel Drives!*

See Sections "I,J,K,L"

ROCK SOLID

DEPENDABILITY

PowerTorque® Shaft Mount Reducers

*A Competitive
Interchangeable Design*

See Section "G"



DuraLine™ Mounted Bearings

*A Competitive Alternative
without Sacrificing Reliability!*

See Section "N"



MinaGear™ Subfractional Gearmotors

Power in a Compact Package!

See Section "P"



APPLICATION ORIENTED

Your application may be entirely different than the ones pictured on this page, but our customers have come from a multitude of industries over the past one-hundred years we've been in business. Our products are used in material handling, packaging, medical equipment, food processing, transportation, construction, aerospace and marine applications ...and it doesn't stop here. Over 50% of what we manufacture is either modified standard products or completely customized.

We know time is valuable, that's why you can count on HUB CITY for support, services and solutions to simplify your installation. Select from a complete line of standard or custom design products.

MEDICAL
FOOD PROCESSING
CONSTRUCTION
PACKAGING
TRANSPORTATION
AEROSPACE
AGRICULTURE
MATERIAL HANDLING
RECREATION
AND MANY MORE...



Standard & custom units are built for countless applications.



CUSTOM PRODUCTS

HUB CITY provides technically advanced products to meet your custom application. Our engineering team offers complete support from design and prototypes to the manufactured unit.

HUB CITY Custom Products Are Unlimited:

Outdoor Power Equipment

- Used to power hand-held outdoor equipment such as: rubber paddle brooms, nylon bristle brushes & cultivator attachments
- Ratios: 40:1 and 49:1
- Input speeds: 5,000 to 10,000 RPM
- Output torque ratings: 110 to 150 IN-LB
- 1.1 HP (49:1) and 1.5 HP (40:1) with 2-cycle engines
- Lubed for life

Military Applications

- Used in military rocket launchers. It raises and lowers the canister, which contains the rockets, positioning them for firing.
- 1:1 spiral bevel gearing & 1.53:1 spiral bevel gearing
- Special paint & corrosion protection applied to all exposed surfaces

Boom Rotation Drives

- Used for rotating the main boom in small utility and electrical maintenance vehicles
- Spur gear mates with internal or external gear teeth, which are part of the main rotation bearing
- Manufactured in several sizes and output flange configurations

Packaging Equipment

- Suitable for production equipment and food processing
- Increases production in packaging machinery: shrink wrap & snack bagging applications, which crimp, seal and cut snack bags
- Manufactured with planetary gearing

Spraying Equipment

- Operates spray pumps in recreational and commercial vehicles. The spray pumps are run by the low speed output shaft, and the double extended high speed input shaft transmits power to the vehicle differential.
- Utilizes our standard Model 180, 5:1, gear design in a special housing

Monorail Drive

- Used in monorail and bottling conveyor application
- Ratios: 19.63:1 to 78.52:1
- Manufactured with or without disengage mechanisms

**Custom
Worm Gear
Reducers**



**Modified
Bevel
Gearboxes**

**Special
Worm
Gear
Drives**



**Custom
Spur Gear
Drives**

**Custom
Worm
Gear
Drive**



**Custom
Helical
Gear
Reducers**

Call us with your specific application.

AT THE HEART OF WHAT DRIVES YOUR WORLD...

Since 1892, HUB CITY has a reputation for producing tough, dependable driveline components for industry and agriculture worldwide. As a world-class manufacturer, HUB CITY provides the technology, expertise and support to perfectly integrate our products into your application. Whether your application requires a standard, modified standard or custom product, HUB CITY will always be at the heart of what drives your world.

Leading Edge Engineering Team Brings You:

- Advanced product design for diverse applications
- Custom designed prototypes for evaluation and testing
- Support from inception to completion of the product design through manufacturing

State-of-the-Art Manufacturing with Capabilities Including:

- Extensive computer numerically controlled (CNC) machines for milling, turning, drilling, boring, threading, grinding, hobbing and gear cutting of barstock, forgings and castings
- Equipment supported by Direct Numerical Control (DNC), Computer-Aided Design and Manufacturing (CAD/CAM), and computer-based systems for Enterprise Resource Planning (ERP)
- Microprocessor-controlled heat treating that carburizes and hardens, through-hardens, induction hardens, or tempers and anneals a variety of materials

World-Class Quality is Assured By:

- Design simplicity and structural integrity
- Comprehensive systems, procedures and work instructions in accordance with ISO-9000 standards
- State-of-the-art testing equipment and laboratory

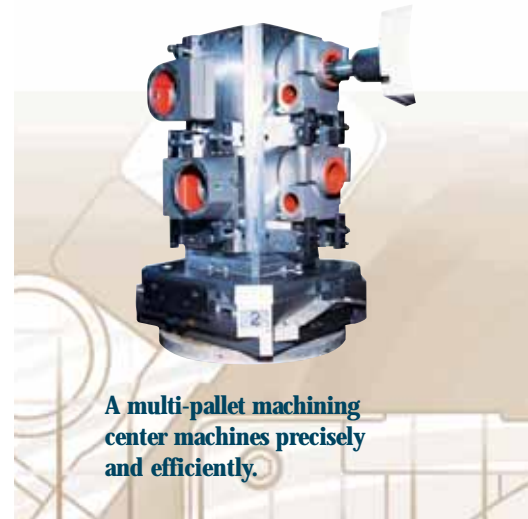

A multi-pallet machining center machines precisely and efficiently.



State-of-the-art testing equipment and comprehensive product testing ensures quality.

Dedicated Customer Service Means Support From:

- Two manufacturing facilities in South Dakota
- Seven Assembly/Distribution Centers conveniently located throughout North America
- Skilled customer service professionals committed to excellence in providing product information and prompt order processing

Application engineers provide advanced product designs and support to meet your exact requirements.



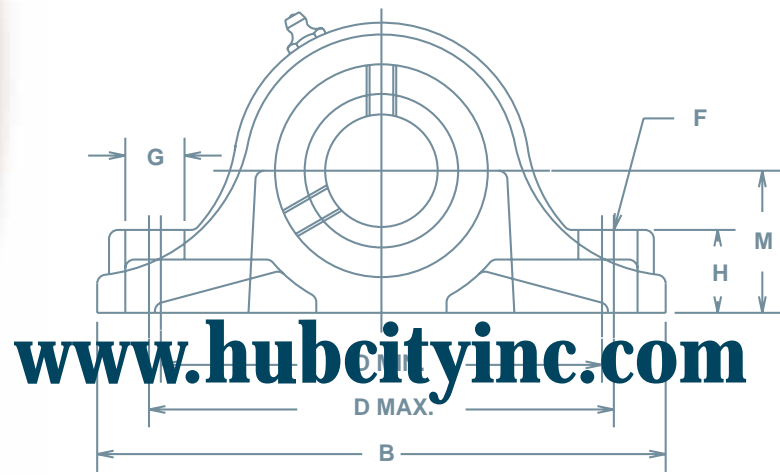

Does your application require CAD drawings? How about a configurator to aid your gear drive selection? Log on to www.hubcityinc.com where you may access our catalog tool for configuring and selecting a gear drive or mounted bearing. Then download our Fast Draft DXF drawings, browse through the standard and custom product overviews, read what's new at the "HUB," and order product literature. Download all of our product literature in an easy to use PDF format. If a custom gear drive is what your are looking for, there are several examples of HUB CITY's custom capabilities featured here.

Do you need to speak to a HUB CITY field salesperson? Contact information is located on the site, as well as a HUB CITY Authorized Distributor directory searchable by zip code.

SOLUTION DRIVEN

CUSTOMER SERVICE

CATALOG TOOLS

CONFIGURATOR

CAD DRAWINGS

CUSTOM PRODUCTS

STANDARD PRODUCTS

LOCATE DISTRIBUTORS

FIELD SALES OFFICES

SUPPORT • SERVICE • SOLUTIONS



Find the HUB CITY field salesperson nearest you.

